

## TPD1S514 USB Charger Over Voltage, Surge and ESD Protection for $V_{BUS}$ PIN

### 1 Features

- Over Voltage Protection at  $V_{BUS\_CON}$  up to 30-V DC
- Precision OVP ( $< \pm 1\%$  Tolerance)
  - Factory programmable  $V_{OVP}$  of 5.6 V to 15 V
- Low  $R_{ON}$  nFET Switch Supports Host and Charging Mode
- Dedicated  $V_{BUS\_POWER}$  pin offers flexible power up options under dead battery condition
- Transient Protection for  $V_{BUS}$  Line:
  - IEC 61000-4-2 Contact Discharge  $\pm 15$  kV
  - IEC 61000-4-2 Air Gap Discharge  $\pm 15$  kV
  - IEC 61000-4-5 Open Circuit Voltage 100 V
    - Precision Clamp circuit limits the  $V_{BUS\_SYS}$  Voltage  $< V_{OVP}$
- Factory Programmable Startup and Soft Start delays
- USB Inrush Current Compliant
- Thermal Shutdown (TSD) Feature

### 2 Applications

- Cell Phones
- Tablets
- eBook
- Portable Media Players
- 5-V, 9-V, and 12-V Power Rails

### 3 Description

The TPD1S514 is a single-chip protection solution for the USB  $V_{BUS}$  line or other power buses. The bidirectional nFET switch ensures safe current flow in both charging and host mode while protecting the internal system circuits from any over voltage condition at the  $V_{BUS\_CON}$  pin. On the  $V_{BUS\_CON}$  pin, this device can handle over voltage protection up to 30-V DC. After the  $\overline{EN}$  pin toggles low, the TPD1S514 waits 20 ms before turning ON the nFET through a soft start delay. TPD1S514 can be factory programmed to multiple  $V_{OVP}$ , start up and soft start delay combinations. See the [Device Comparison](#) table.

#### Device Information<sup>(1)</sup>

DEVICE NAME	PACKAGE	BODY SIZE (NOM)
TPD1S514	WCSP (12)	1.29 mm x 1.99 mm

(1) For all available packages, see the orderable addendum at the end of the datasheet.

#### TPD1S514 Circuit Protection Scheme

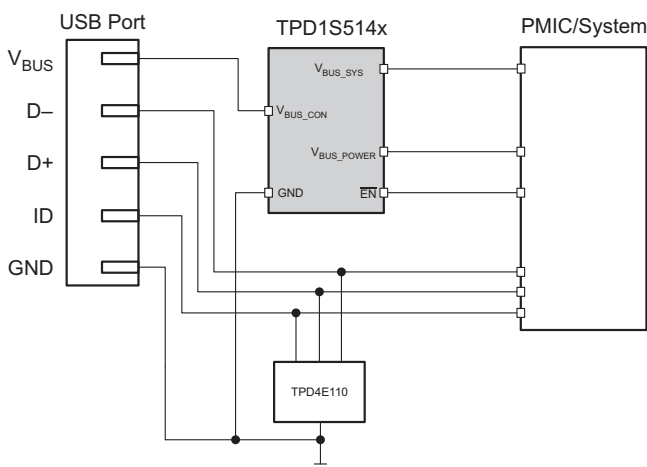

#### TPD1S514 Block Diagram

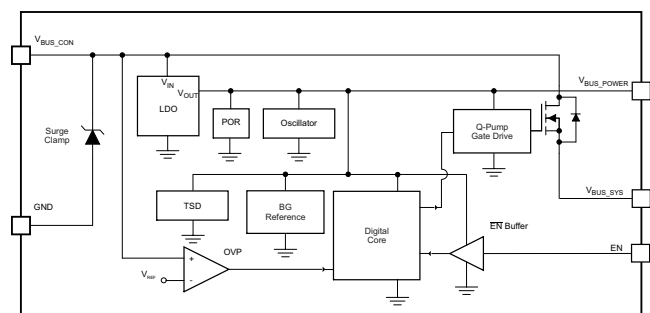

## Table of Contents

<b>1 Features</b> .....	<b>1</b>	7.12 TPD1S514-1 Typical Characteristics .....	<b>9</b>
<b>2 Applications</b> .....	<b>1</b>	<b>8 Detailed Description</b> .....	<b>11</b>
<b>3 Description</b> .....	<b>1</b>	8.1 Overview .....	<b>11</b>
<b>4 Revision History</b> .....	<b>2</b>	8.2 Functional Block Diagram .....	<b>11</b>
<b>5 Device Comparison Table</b> .....	<b>3</b>	8.3 Feature Description .....	<b>11</b>
<b>6 Pin Configuration and Functions</b> .....	<b>3</b>	8.4 Device Functional Modes .....	<b>13</b>
<b>7 Specifications</b> .....	<b>4</b>	<b>9 Application and Implementation</b> .....	<b>14</b>
7.1 Absolute Maximum Ratings .....	<b>4</b>	9.1 Application Information .....	<b>14</b>
7.2 Handling Ratings .....	<b>4</b>	9.2 Typical Application .....	<b>14</b>
7.3 Recommended Operating Conditions .....	<b>5</b>	<b>10 Power Supply Recommendations</b> .....	<b>17</b>
7.4 Thermal Information .....	<b>5</b>	<b>11 Layout</b> .....	<b>18</b>
7.5 Supply Current Consumption .....	<b>5</b>	11.1 Layout Guidelines .....	<b>18</b>
7.6 Electrical Characteristics $\overline{\text{EN}}$ Pin .....	<b>6</b>	11.2 Layout Example .....	<b>18</b>
7.7 Thermal Shutdown Feature .....	<b>6</b>	<b>12 Device and Documentation Support</b> .....	<b>19</b>
7.8 Electrical Characteristics nFET Switch .....	<b>6</b>	12.1 Trademarks .....	<b>19</b>
7.9 Electrical Characteristics OVP Circuit .....	<b>7</b>	12.2 Electrostatic Discharge Caution .....	<b>19</b>
7.10 Electrical Characteristics $V_{\text{BUS\_POWER}}$ Circuit .....	<b>7</b>	12.3 Glossary .....	<b>19</b>
7.11 Timing Requirements .....	<b>8</b>	<b>13 Mechanical, Packaging, and Orderable Information</b> .....	<b>19</b>

## 4 Revision History

Changes from Revision A (July 2014) to Revision B	Page
• Changed Body size to fix rounding error. ....	<b>1</b>

Changes from Original (April 2014) to Revision A	Page
• Removed Preview status of TPD1S514-2. ....	<b>1</b>
• Updated Device Comparison table. ....	<b>3</b>
• Updated Electrical Characteristics OVP Circuit table. ....	<b>7</b>

## 5 Device Comparison Table

TPD1S514 Family	V <sub>OVP</sub> (V)			V <sub>OVP_HYS</sub> (mV)	V <sub>BUS_POWER</sub> (V) <sup>(1)</sup>		T_Startup delay (ms) options	T_Soft Start (ms) options
	Min	Typ	Max	Typ	Min	Typ	Typ	Typ
TPD1S514-1	5.9	5.95	5.99	100	4.7	4.95	20	3.5
TPD1S514-2	9.9	9.98	10.05	100	4.7	4.95		
TPD1S514-3 (Preview)	13.2	13.32	13.4	100	4.7	4.95		
TPD1S514-4	5.9	5.95	5.99	20	6.2	6.48		
TPD1S514-x	5.6 V – 15 V <sup>(1)</sup>			100	4.7	4.95	5, 20, 30, or 150 <sup>(1)(2)</sup>	0.1, 3.5, 4.9, or 6.7 <sup>(1)(2)</sup>

- (1) With V<sub>BUS\_CON</sub> > 6.5V. See Sections [V<sub>BUS\\_POWER</sub>](#), [TPD1S514-1](#), [TPD1S514-2](#), [TPD1S514-3](#) and [V<sub>BUS\\_POWER</sub>](#), [TPD1S514](#) for full description.
- (2) These parameters are factory programmable. See the [Manufacturer Programmable Internal Startup, SoftStart Delays, and OVP](#) section and contact your local sales representative.

## 6 Pin Configuration and Functions

**TPD1S514 WCSP (YZ) PIN MAPPING  
(TOP SIDE/SEE-THROUGH VIEW)**

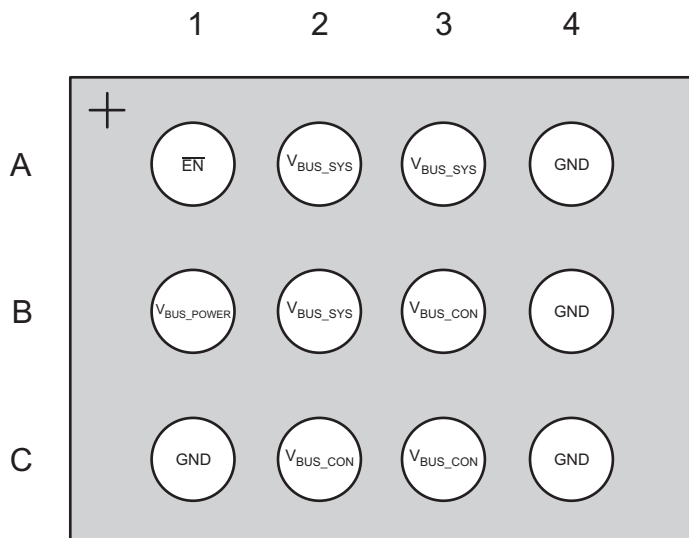

**Pin Functions**

PIN		I/O	DESCRIPTION
NAME	NO.		
$\overline{\text{EN}}$	A1	I	Enable Active-Low Input. Drive $\overline{\text{EN}}$ low to enable the switch. Drive $\overline{\text{EN}}$ high to disable the switch.
V <sub>BUS_POWER</sub>	B1	O	5 V Power source controlled by V <sub>BUS_CON</sub> .
V <sub>BUS_SYS</sub>	A2, A3, B2	IO	Connect to internal VBUS plane.
V <sub>BUS_CON</sub>	B3, C2, C3	IO	Connect to USB connector VBUS pin; IEC61000-4-2 ESD protection IEC61000-4-5 Surge protection.
GND	A4, B4, C1, C4	G	Connect to PCB ground plane.

## 7 Specifications

### 7.1 Absolute Maximum Ratings<sup>(1)(2)</sup>

over operating free-air temperature range (unless otherwise noted)

		MIN	MAX	UNIT		
V <sub>BUS_CON</sub>	Supply voltage from USB connector	-0.3	30	V		
V <sub>BUS_SYS</sub>	Internal Supply DC voltage Rail on the PCB	-0.3	20	V		
I <sub>BUS</sub>	Continuous input current on V <sub>BUS_CON</sub> pin <sup>(3)</sup>		3.5	A		
I <sub>OUT</sub>	Continuous output current on V <sub>BUS_CON</sub> pin <sup>(3)</sup>		3.5	A		
I <sub>PEAK</sub>	Peak Input and Output Current on V <sub>BUS_CON</sub> ; V <sub>BUS_SYS</sub> pin (10 ms)		8	A		
I <sub>DIODE</sub>	Continuous forward current through the FET body diode		1	A		
I <sub>POWER</sub>	Continuous Current through V <sub>BUS_POWER</sub>		1	mA		
V <sub>EN</sub>	Voltage on Input pin ( $\overline{EN}$ )		7	V		
V <sub>BUS_POWER</sub>	Continuous Voltage at V <sub>BUS_POWER</sub>	TPD1S514-1	See <sup>(4)</sup>	V		
		TPD1S514-2	See <sup>(4)</sup>			
		TPD1S514-3 (Preview)	See <sup>(4)</sup>			
		TPD1S514-4	See <sup>(4)</sup>			
T <sub>STG</sub>	Storage temperature range	-65	150	°C		
T <sub>A</sub>	Operating Free Air Temperature		-40	85	°C	
		IEC 61000-4-5 Peak Pulse Current (t <sub>p</sub> = 8/20µs)	V <sub>BUS_CON</sub> pin		30	A
		IEC 61000-4-5 Peak Pulse Power (t <sub>p</sub> = 8/20µs)	V <sub>BUS_CON</sub> pin		900	W
		IEC 61000-4-5 Open circuit voltage (t <sub>p</sub> = 1.2/50 µs)	V <sub>BUS_CON</sub> pin		100	V
C <sub>LOAD</sub>	Output load capacitance		0.1	100	µF	
C <sub>CON</sub>	Input capacitance		0.1	50	µF	
C <sub>POW</sub>	V <sub>BUS_POWER</sub> Capacitance		0.1	4.7	µF	

- (1) Stresses above these ratings may cause permanent damage. Exposure to absolute maximum conditions for extended periods may degrade device reliability. These are stress ratings only, and functional operation of the device at these or any other conditions beyond those specified is not implied.
- (2) The algebraic convention, whereby the most negative value is a minimum and the most positive value is a maximum.
- (3) Thermal limits and power dissipation limits must be observed.
- (4) 6.9 V or V<sub>BUS\_CON</sub> + 0.3 V, whichever is smaller.

### 7.2 Handling Ratings

		MIN	MAX	UNIT		
T <sub>stg</sub>	Storage temperature range			°C		
V <sub>(ESD)</sub>	Electrostatic discharge	Human body model (HBM), per ANSI/ESDA/JEDEC JS-001, all pins <sup>(1)</sup>	-2000	+2000	V	
		Charged device model (CDM), per JEDEC specification JESD22-C101, all pins <sup>(2)</sup>	-500	500	V	
		IEC 61000-4-2 Contact Discharge	V <sub>BUS_CON</sub> pin	-15	+15	kV
		IEC 61000-4-2 Air-gap Discharge	V <sub>BUS_CON</sub> pin	-15	+15	kV

- (1) JEDEC document JEP155 states that 500-V HBM allows safe manufacturing with a standard ESD control process. Pins listed as 2000 V may actually have higher performance.
- (2) JEDEC document JEP157 states that 250-V CDM allows safe manufacturing with a standard ESD control process. Pins listed as 500 V may actually have higher performance.

### 7.3 Recommended Operating Conditions

over operating free-air temperature range (unless otherwise noted)

			MIN	TYP	MAX	UNIT
V <sub>BUS_CON</sub>	Supply voltage from USB connector	TPD1S514-1	3.5	5	5.9	V
		TPD1S514-2	3.5	9	9.9	
		TPD1S514-3 (Preview)	3.5	12	13.2	
		TPD1S514-4	3.5	5	5.9	
V <sub>BUS_SYS</sub>	Internal Supply DC voltage Rail on the PCB	TPD1S514-1	3.9	5	5.9	V
		TPD1S514-2	3.9	9	9.9	
		TPD1S514-3 (Preview)	3.9	12	13.2	
		TPD1S514-4	3.9	5	5.9	
C <sub>LOAD</sub>	Output load capacitance	V <sub>BUS_SYS</sub> pin	2.2		μF	
C <sub>CON</sub>	Input capacitance	V <sub>BUS_CON</sub> pin	1		μF	
C <sub>POWER</sub>	Capacitance on V <sub>BUS_POWER</sub>	V <sub>BUS_POWER</sub> pin	1		μF	
T <sub>A</sub>	Operating free-air temperature		-40		85	°C

### 7.4 Thermal Information

THERMAL METRIC <sup>(1)</sup>		TPD1S514	UNIT
		YZ	
		12 PINS	
R <sub>θJA</sub>	Junction-to-ambient thermal resistance	89	°C/W
R <sub>θJC(top)</sub>	Junction-to-case (top) thermal resistance	0.6	
R <sub>θJB</sub>	Junction-to-board thermal resistance	16.3	
Ψ <sub>JT</sub>	Junction-to-top characterization parameter	2.7	
Ψ <sub>JB</sub>	Junction-to-board characterization parameter	16.2	
R <sub>θJC(bot)</sub>	Junction-to-case (bottom) thermal resistance	n/a	

 (1) For more information about traditional and new thermal metrics, see the *IC Package Thermal Metrics* application report, [SPRA953](#).

### 7.5 Supply Current Consumption

over operating free-air temperature range (unless otherwise noted)

PARAMETER		TEST CONDITIONS	DEVICE NAME	TYP	MAX	UNIT
I <sub>V<sub>BUS_SLEEP</sub></sub>	V <sub>BUS_CON</sub> Operating Current Consumption	Measured at V <sub>BUS_CON</sub> pin, EN = 5 V	V <sub>BUS_CON</sub> = 5 V	150	245	μA
			V <sub>BUS_CON</sub> = 9 V	176	281	
			V <sub>BUS_CON</sub> = 12 V	195	308	
			V <sub>BUS_CON</sub> = 5 V	150	245	
I <sub>V<sub>BUS</sub></sub>	V <sub>BUS_CON</sub> Operating Current Consumption	Measured at V <sub>BUS_CON</sub> pin, EN = 0 V and no load	V <sub>BUS_CON</sub> = 5 V	228	354	μA
			V <sub>BUS_CON</sub> = 9 V	250	413	
			V <sub>BUS_CON</sub> = 12 V	337	456	
			V <sub>BUS_CON</sub> = 5 V	228	354	
I <sub>V<sub>BUS_SYS</sub></sub>	V <sub>BUS_SYS</sub> Operating Current Consumption	Measured at V <sub>BUS_SYS</sub> pin, V <sub>BUS_CON</sub> = Hi-Z, EN = 0 V	V <sub>BUS_SYS</sub> = 5 V	210	354	μA
			V <sub>BUS_SYS</sub> = 9 V	250	424	
			V <sub>BUS_SYS</sub> = 12 V	333	461	
			V <sub>BUS_SYS</sub> = 5 V	210	354	
I <sub>HOST_LEAK</sub>	Host Mode Leakage current	Measured at V <sub>BUS_SYS</sub> pin, V <sub>BUS_CON</sub> = Hi-Z, EN = 5 V	V <sub>BUS_SYS</sub> = 5 V	90	218	μA
			V <sub>BUS_SYS</sub> = 9 V	290	491	
			V <sub>BUS_SYS</sub> = 12 V	506	696	
			V <sub>BUS_SYS</sub> = 5 V	90	218	

## 7.6 Electrical Characteristics $\overline{\text{EN}}$ Pin

over operating free-air temperature range (unless otherwise noted)

PARAMETER			TEST CONDITIONS	MIN	TYP	MAX	UNIT
$V_{IH}$	High-level input voltage	$\overline{\text{EN}}$	$V_{BUS\_CON} = 5\text{ V}$	1.2		6	V
$V_{IL}$	Low-level input voltage	$\overline{\text{EN}}$	$V_{BUS\_CON} = 5\text{ V}$	0		0.8	V
$I_{IL}$	Input Leakage Current	$\overline{\text{EN}}$	$V_{\overline{\text{EN}}} = 0\text{ V}, V_{BUS\_CON} = 5\text{ V}$			1	$\mu\text{A}$
$I_{IH}$	Input Leakage Current	$\overline{\text{EN}}$	$V_{\overline{\text{EN}}} = 5\text{ V}, V_{BUS\_CON} = 5\text{ V}$			10	$\mu\text{A}$

## 7.7 Thermal Shutdown Feature

over operating free-air temperature range (unless otherwise noted)

PARAMETER		TEST CONDITIONS	MIN	TYP	MAX	UNIT
$T_{SHDN}$	Thermal Shutdown	$V_{BUS\_CON} = 5\text{ V}, \overline{\text{EN}} = 0\text{ V}$ , Junction temperature decreases from thermal shutdown level until the nFET switch turns off.		145		$^{\circ}\text{C}$
	Thermal Shutdown Hysteresis	$V_{BUS\_CON} = 5\text{ V}, \overline{\text{EN}} = 0\text{ V}$ , Junction temperature decreases from thermal shutdown level until the nFET switch turns on.		25		$^{\circ}\text{C}$

## 7.8 Electrical Characteristics nFET Switch

 $T = 25^{\circ}\text{C}$ 

PARAMETER		TEST CONDITIONS		MIN	TYP	MAX	UNIT
$R_{ON}$	Switch ON Resistance	$V_{BUS\_CON} = 5\text{ V}, I_{OUT} = 1\text{ A}$	TPD1S514-1		39	50	m $\Omega$
		$V_{BUS\_CON} = 9\text{ V}, I_{OUT} = 1\text{ A}$	TPD1S514-2		39	50	
		$V_{BUS\_CON} = 12\text{ V}, I_{OUT} = 1\text{ A}$	TPD1S514-3 (Preview)		39	50	
		$V_{BUS\_CON} = 5\text{ V}, I_{OUT} = 1\text{ A}$	TPD1S514-4		39	50	

## 7.9 Electrical Characteristics OVP Circuit

T = 25°C

PARAMETER		TEST CONDITIONS		MIN	TYP	MAX	UNIT	
V <sub>OVP</sub>	Input voltage protection threshold	V <sub>BUS_CON</sub>	V <sub>BUS_CON</sub> increasing from 0 V to 20 V	TPD1S514-1	5.90	5.95	5.99	V
				TPD1S514-2	9.9	9.98	10.05	
				TPD1S514-3 (Preview)	13.5	13.75	14	
				TPD1S514-4	5.90	5.95	5.99	
V <sub>HYS_OVP</sub>	Hysteresis on OVP	V <sub>BUS_CON</sub>	V <sub>BUS_CON</sub> decreasing from 20 V to 0 V	TPD1S514-1	100		mV	
				TPD1S514-2	100			
				TPD1S514-3 (Preview)	100			
				TPD1S514-4	20			
V <sub>UVLO</sub>	Input under voltage lockout	V <sub>BUS_CON</sub>	V <sub>BUS_CON</sub> voltage rising from 0 V to 5 V	2.7	3.1	3.5	V	
V <sub>HYS_UVLO</sub>	Hysteresis on UVLO	V <sub>BUS_CON</sub>	Difference between rising and falling UVLO thresholds	80			mV	
V <sub>UVLO_FALLING</sub>	Input under voltage lockout	V <sub>BUS_CON</sub>	V <sub>BUS_CON</sub> voltage falling from 5 V to 0 V	2.6	3.0	3.4	V	
V <sub>UVLO_SYS</sub>	V <sub>BUS_SYS</sub> under voltage lockout	V <sub>BUS_SYS</sub>	V <sub>BUS_SYS</sub> voltage rising from 0 V to 5 V	2.8	3.7	4.3	V	
V <sub>HYS_UVLO_SYS</sub>	V <sub>BUS_SYS</sub> UVLO Hysteresis	V <sub>BUS_SYS</sub>	Difference between rising and falling UVLO thresholds on V <sub>BUS_SYS</sub>	500			mV	
V <sub>UVLO_SYS_FALLING</sub>	V <sub>BUS_SYS</sub> under voltage lockout	V <sub>BUS_SYS</sub>	V <sub>BUS_SYS</sub> voltage falling from 5 V to 0 V	2.6	3.0	3.4	V	

## 7.10 Electrical Characteristics V<sub>BUS\_POWER</sub> Circuit

over operating free-air temperature range (unless otherwise noted)

PARAMETER		TEST CONDITIONS		MIN	TYP	MAX	UNIT
V <sub>CLAMP</sub>	Output Voltage on V <sub>BUS_POWER</sub> during OVP	V <sub>BUS_CON</sub> = 20 V	TPD1S514-1	5.0		5.5	V
			TPD1S514-2	5.0		5.5	
			TPD1S514-3 (Preview)	5.0		5.5	
			TPD1S514-4	6.48	6.68		
V <sub>BUS_POWER</sub>	Output Voltage on V <sub>BUS_POWER</sub> during normal operation	V <sub>BUS_CON</sub> = 5 V; I <sub>BUS_POWER</sub> = 1 mA;	TPD1S514-1	4.7	4.95	V	
			TPD1S514-2	4.7	4.95		
			TPD1S514-3 (Preview)	4.7	4.95		
			TPD1S514-4	4.7	4.98		
I <sub>BUS_POWER_MAX</sub>	Output Current on V <sub>BUS_POWER</sub>	V <sub>BUS_CON</sub> = 5 V – 15 V				3	mA

### 7.11 Timing Requirements

over operating free-air temperature range (unless otherwise noted)

PARAMETER		TEST CONDITIONS	MIN	TYP	MAX	UNIT
$t_{DELAY}$	USB Charging Turn-ON Delay	Measured from $\overline{EN}$ asserted LOW to nFET begins to Turn ON, excludes soft-start time	TPD1S514-1	20		ms
			TPD1S514-2			
			TPD1S514-3 (Preview)			
			TPD1S514-4			
$t_{SS}$	USB Charging rise time (Soft Start Delay)	Measure from $V_{BUS\_SYS}$ rises above 25% (with 1 M $\Omega$ load/ NO $C_{LOAD}$ )	TPD1S514-1	3.5		ms
			TPD1S514-2			
			TPD1S514-3 (Preview)			
			TPD1S514-4			
$t_{OFF\_DELAY}$	USB Charging Turn-OFF time	Measured from $\overline{EN}$ asserted High to $V_{BUS\_SYS}$ falling to 10% with $R_{LOAD} = 10\Omega$ and No $C_{LOAD}$ on $V_{BUS\_SYS}$	TPD1S514-1	5.5		$\mu$ s
			TPD1S514-2			
			TPD1S514-3 (Preview)			
			TPD1S514-4			
<b>OVER VOLTAGE PROTECTION</b>						
$t_{OVP\_response}$	OVP Response time	Measured from OVP Condition to FET Turn OFF <sup>(1)</sup>			100	ns

(1) Specified by design, not production tested

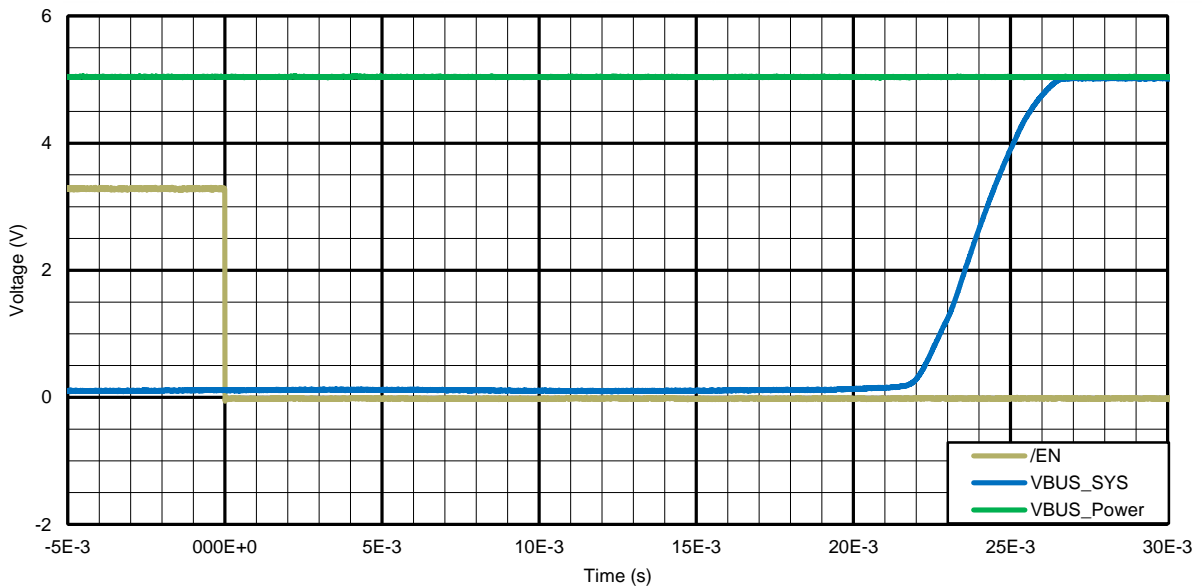
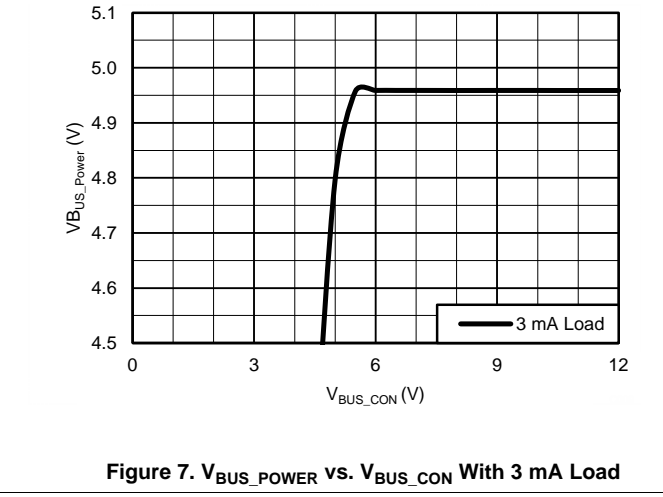
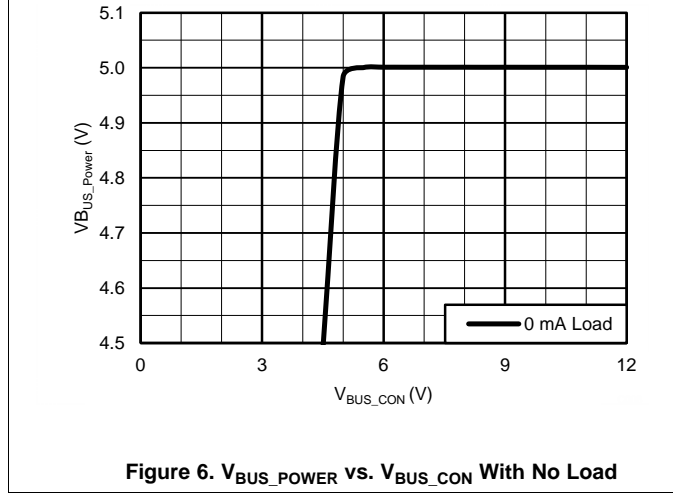
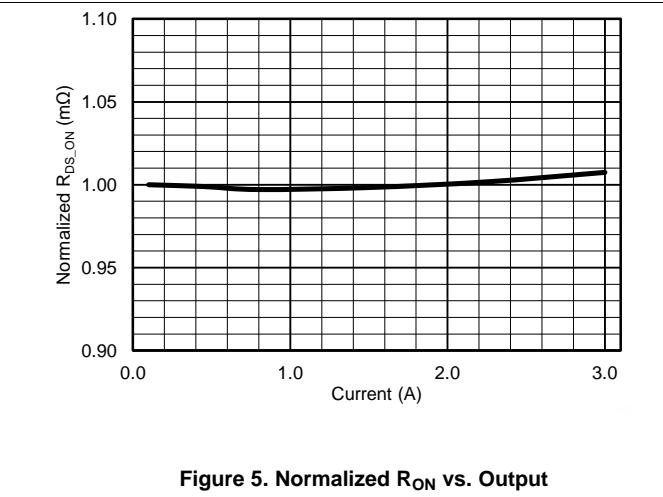
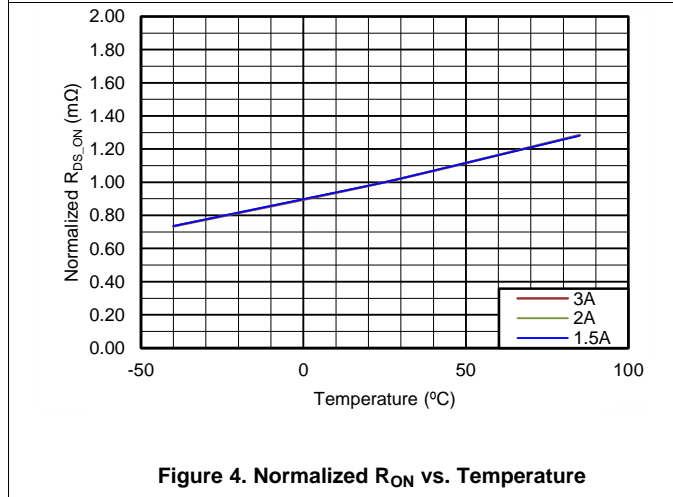
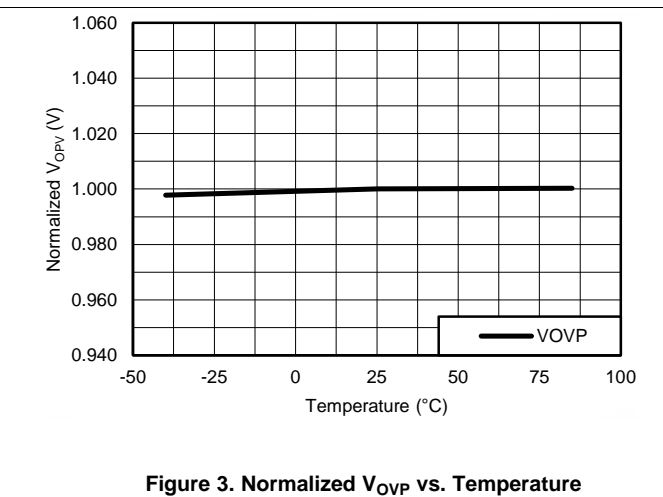
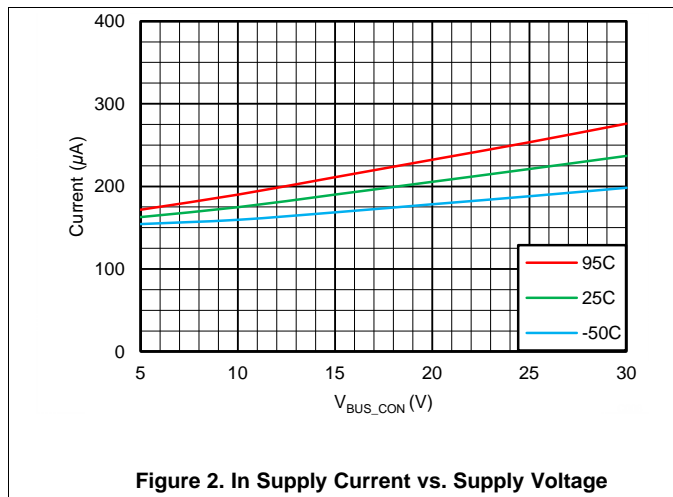

Figure 1. TPD1S514-1 Response to set  $\overline{EN}$  low

### 7.12 TPD1S514-1 Typical Characteristics



**TPD1S514**

SLVSCF6B – APRIL 2014 – REVISED SEPTEMBER 2014

www.ti.com

**TPD1S514-1 Typical Characteristics (continued)**

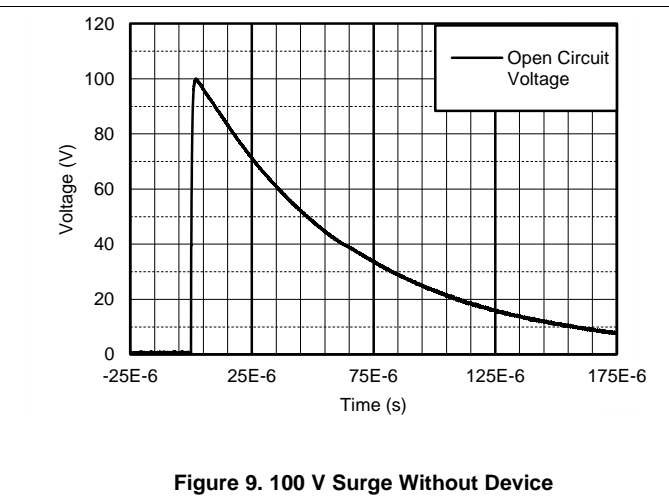
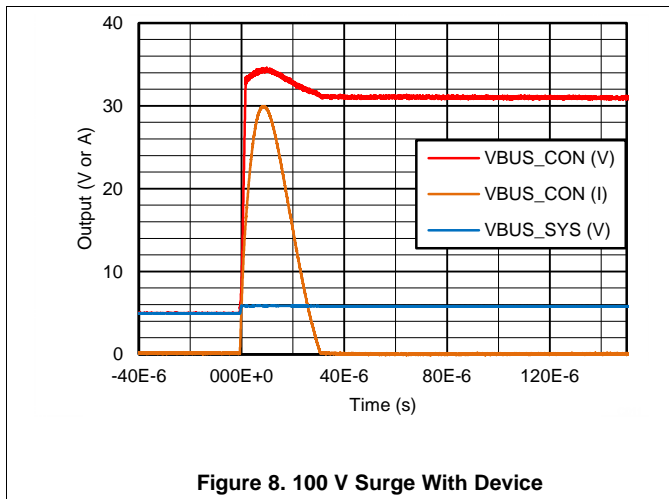

## 8 Detailed Description

### 8.1 Overview

The TPD1S514 provides a single-chip ESD, surge, and over voltage protection solution for portable USB Charging and Host interfaces. It offers over voltage protection at the  $V_{BUS\_CON}$  pin up to 30-V DC. The TPD1S514 offers an ESD and Precision Clamp for the  $V_{BUS\_CON}$  pin, thus eliminating the need for external TVS clamp circuits in the application.

The TPD1S514 has an internal oscillator and charge pump which controls turning ON the internal nFET switch. The internal oscillator controls the timers which enable the charge pump. If  $V_{BUS\_CON}$  is less than  $V_{OVP}$ , the internal charge pump is enabled. After a 20 ms internal delay, the charge-pump starts-up, and turns ON the internal nFET switch through a soft start. If at any time  $V_{BUS\_CON}$  rises above  $V_{OVP}$ , the nFET switch is turned OFF within 100 ns.

The TPD1S514 also has a  $V_{BUS\_POWER}$  pin which follows  $V_{BUS\_CON}$  up to 4.9 V at 3 mA (except for TPD1S514, which follows  $V_{BUS\_CON}$  up to 6.48 V, after which it is regulated to that voltage) to power the system from  $V_{BUS\_CON}$ . In the case where the system battery state cannot power the system, voltage from an external charger can be provided to power the system.  $V_{BUS\_POWER}$  is supplied by an always on LDO regulator supplied by  $V_{BUS\_CON}$ .  $V_{BUS\_POWER}$  output voltage remains regulated to 4.9 V (except for TPD1S514, which follows  $V_{BUS\_CON}$  up to 6.48 V, after which it is regulated to that voltage) at up to 30-V DC on  $V_{BUS\_CON}$  and during IEC61000-4-5 surge events of up to 100 V open circuit voltage on  $V_{BUS\_CON}$ .

### 8.2 Functional Block Diagram

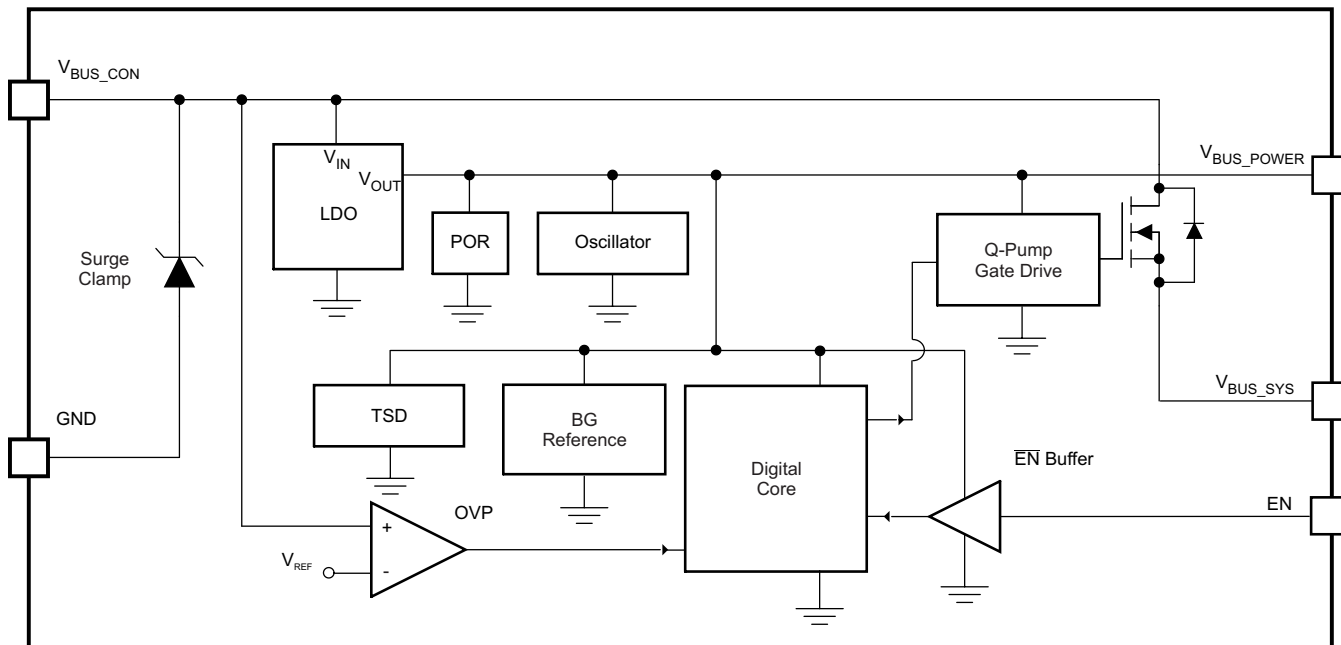

### 8.3 Feature Description

#### 8.3.1 Over Voltage Protection on $V_{BUS\_CON}$ up to 30 V DC

When the  $V_{BUS\_CON}$  voltage rises above  $V_{OVP}$ , the internal nFET switch is turned OFF, removing power from the system side.  $V_{BUS\_CON}$  can tolerate up to 30-V DC. The response to over voltage is very rapid, with the nFET switch turning off in less than 100 ns. When the  $V_{BUS\_CON}$  voltage returns back to below  $V_{OVP} - V_{HYS\_OVP}$ , the nFET switch is turned ON again after an internal delay of  $t_{OVP\_RECOV}$  ( $t_{DELAY}$ ). This time delay ensures that the  $V_{BUS\_CON}$  supply has stabilized before turning the switch back on. After  $t_{OVP\_RECOV}$ , the TPD1S514 turns on the nFET through a soft start. Once the OVP condition is cleared the nFET is turned completely ON.

## Feature Description (continued)

### 8.3.2 Precision OVP (< ±1% Tolerance)

1% OVP trip threshold accuracy allows use of the entire input charging range while protecting sensitive system-side components from overvoltage conditions.

### 8.3.3 Manufacturer Programmable Internal Startup, SoftStart Delays, and OVP

TPD1S514 with  $V_{BUS\_POWER} = 4.95\text{ V}$  can be manufactured pre-programmed with the startup time,  $t_{DELAY}$ , ranging from 5 ms to 150 ms. Also, the SoftStart,  $t_{SS}$ , can be manufactured pre-programmed with a range of 0.1 ms to 6.7 ms. Also, OVP can be manufactured to protect at levels of 5.6 V – 15 V in 30 mV steps. Any of these three parameters can be configured independent of the others. In all cases  $V_{BUS\_POWER} = 4.95\text{ V}$ .

- a. Factory programmable parameters:
  - i.  $t_{DELAY}$ : 5 ms, 20 ms, 30ms, or 150 ms
  - ii.  $t_{SS}$ : 0.1 ms, 3.5 ms, 4.9 ms, or 6.7 ms
  - iii. OVP: 5.6 V – 15 V in 30 mV steps

### 8.3.4 Low $R_{ON}$ nFET Switch Supports Host and Charging Mode

The nFET switch has a total on resistance ( $R_{ON}$ ) of 39 mΩ. This equates to a voltage drop of less than 140 mV when charging at the maximum 3.5 A current level. Such low  $R_{ON}$  helps provide maximum potential to the system as provided by an external charger or by the system when in Host Mode.

### 8.3.5 $V_{BUS\_POWER}$ , TPD1S514-1, TPD1S514-2, TPD1S514-3

The  $V_{BUS\_POWER}$  pin provides up to 3 mA and 5 V for powering the system using  $V_{BUS\_CON}$ .  $V_{BUS\_POWER}$  follows  $V_{BUS\_CON}$  after 3.5 V and up to the regulated 5 V. In the case where the system battery state cannot power the system, voltage from an external charger can power the system.  $V_{BUS\_POWER}$  is supplied by an always on LDO regulator supplied by  $V_{BUS\_CON}$ . The  $V_{BUS\_POWER}$  output voltage remains regulated to 5 V at up to 30-V DC on  $V_{BUS\_CON}$  and during IEC61000-4-5 surge events of up to 100 V.

### 8.3.6 $V_{BUS\_POWER}$ , TPD1S514

The  $V_{BUS\_POWER}$  pin provides up to 3 mA and 6.48 V for powering the system using  $V_{BUS\_CON}$ .  $V_{BUS\_POWER}$  follows  $V_{BUS\_CON}$  after 3.5 V and up to the regulated 6.48 V. In the case where the system battery state cannot power the system, voltage from an external charger can be provided to power the system.  $V_{BUS\_POWER}$  is supplied by an always on LDO regulator supplied by  $V_{BUS\_CON}$ . The  $V_{BUS\_POWER}$  output voltage remains regulated to 6.48 V at up to 30-V DC on  $V_{BUS\_CON}$  and during IEC61000-4-5 surge events of up to 100 V.

### 8.3.7 Powering the System When Battery is Discharged

There are two methods for powering the system under a dead battery condition. Case 1: The  $\overline{EN}$  pin can be tied to ground so that the nFET is always ON (when  $V_{UVLO} < V_{BUS\_CON} < V_{OVP}$ ) and an external charger can power VBUS. Case 2: If  $\overline{EN}$  is controlled by a Power Management Unit (PMIC) or other logic,  $V_{BUS\_POWER}$  can be used to power the PMIC.

### 8.3.8 ±15 kV IEC61000-4-2 Level 4 ESD Protection

The  $V_{BUS\_CON}$  pin can withstand ESD events up to ±15 kV Contact and Air-Gap. An ESD clamp diverts the current to ground.

### 8.3.9 100 V IEC61000-4-5 μs Surge Protection

The  $V_{BUS\_CON}$  pin can withstand surge events up to 100 V open circuit voltage ( $V_{PP}$ ), or 900 W. A Precision Clamp diverts the current to ground and active circuitry switches OFF the nFET earlier than 100 ns before an overvoltage can get through to  $V_{BYS\_SYS}$ . The ultra-fast response time of TPD1S514 holds the voltage on  $V_{BUS\_SYS}$  to less than  $V_{OVP}$  during surge events of up to 100  $V_{PP}$ .

## Feature Description (continued)

### 8.3.10 Startup and OVP Recovery Delay

Upon startup or recovering from an over voltage, TPD1S514 has a built in startup delay. An internal oscillator controls a charge pump to control the delay. Once a manufactured pre-programmed time,  $t_{DELAY}$ , has elapsed, the charge pump is enabled which turns ON the nFET. A manufactured pre-programmed soft start,  $t_{SS}$ , is used when turning ON the nFET. These start delays,  $t_{DELAY} + t_{SS}$ , work together to meet USB Inrush Current compliance.

### 8.3.11 Thermal Shutdown

TPD1S514 has an over-temperature protection circuit to protect against system faults or improper use. The basic function of the thermal shutdown (TSD) circuit is to sense when the junction temperature has exceeded the absolute maximum rating and shuts down the device until the junction temperature has cooled to a safe level.

## 8.4 Device Functional Modes

### 8.4.1 Operation With $V_{BUS\_CON} < 3.5\text{ V}$ (Minimum $V_{BUS\_CON}$ )

TPD1S514 operates normally (nFET ON) with input voltages above 3.5 V. The maximum UVLO voltage is 3.5 V and the device will operate at input voltages above 3.5 V. The typical UVLO voltage is 3.1 V and the device may operate at input voltages above that point. The device may also operate at input voltages as low as 2.7 V, the minimum UVLO. At input voltages between 0.6 V and 1.2 V, the state of output pins may not be controlled internally.

### 8.4.2 Operation With $V_{BUS\_CON} > V_{OVP}$

TPD1S514 operates normally (nFET ON) with input voltages below  $V_{OVP\_min}$ . The typical OVP voltage is  $V_{OVP\_TYP}$  and the device may operate at input voltages below that point. The device may also operate at input voltages as high as  $V_{OVP\_MAX}$ .

Device Name	$V_{OVP}$		
	MIN	TYP	MAX
TPD1S514-1	5.9	5.95	5.99
TPD1S514-2	9.9	9.98	10.05
TPD1S514-3 (Preview)	13.2	13.32	13.4
TPD1S514-4	5.9	5.95	5.99

### 8.4.3 OTG Mode

The TPD1S514 UVLO and OVP voltages are referenced to  $V_{BUS\_CON}$  voltage. In OTG mode,  $V_{BUS\_SYS}$  is driving the  $V_{BUS\_CON}$ . Under this situation, initially  $V_{BUS\_CON}$  is powered through the body diode of the nFET by  $V_{BUS\_SYS}$ . Once the UVLO threshold on  $V_{BUS\_CON}$  is met, the nFET turns ON. If there is a short to ground on  $V_{BUS\_CON}$  the OTG supply is expected to limit the current.

## 9 Application and Implementation

### NOTE

Information in the following applications sections is not part of the TI component specification, and TI does not warrant its accuracy or completeness. TI's customers are responsible for determining suitability of components for their purposes. Customers should validate and test their design implementation to confirm system functionality.

### 9.1 Application Information

The devices offer  $V_{BUS}$  port protection implementing UVLO and OVP, with an LDO supplied  $V_{BUS\_POWER}$  pin to regulate an output supply pin of 3 mA at 5 V (except for TPD1S514, which follows  $V_{BUS\_CON}$  up to 6.48 V, after which it is regulated to that voltage). The  $V_{BUS\_POWER}$  pin can be used to power the system from an external source on  $V_{BUS\_CON}$  in case the system's battery state cannot power the system.

### 9.2 Typical Application

#### 9.2.1 TPD1S514-1 USB 2.0/3.0 Case 1: Always Enabled

The  $\overline{EN}$  pin can be tied to ground so that the nFET is ON when  $V_{UVLO} < V_{BUS\_CON} < V_{OVP}$  and an external charger can power  $V_{BUS}$ .  $V_{BUS\_POWER}$  can be left floating.

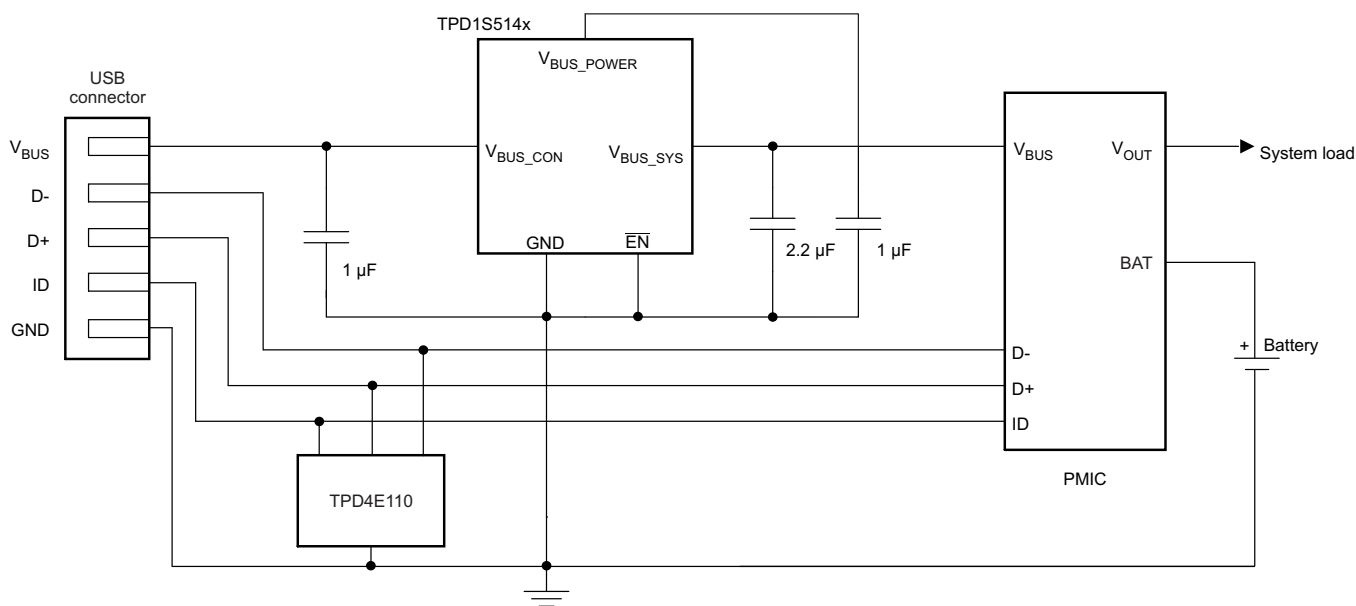

Figure 10. Always on, TPD1S514-1

#### 9.2.1.1 Design Requirements

For this example, use the following table as input parameters:

Design Parameters	Example Value
Signal range on $V_{BUS\_CON}$	3.5 V – 5.9 V
Signal range on $V_{BUS\_SYS}$	3.9 V – 5.9 V
Signal on $\overline{EN}$	Tie to system ground plane

### 9.2.1.2 Detailed Design Procedure

To begin the design process the designer needs to know the  $V_{BUS}$  voltage range.

#### 9.2.1.2.1 $V_{BUS}$ Voltage Range

The UVLO trip-point is a maximum 3.5 V and the OVP trip-point is a minimum 5.9 V. This provides some headroom for the USB 2.0 specified minimum 4.4 V (Low-power) or 4.75 V (Full-power) and 5.25 V maximum; or the USB 3.0 specified minimum 4.45 V and 5.25 V maximum.

#### 9.2.1.2.2 Discharged Battery

Connecting  $\overline{EN}$  to ground sets the part active at all times. OVP and UVLO are always active, even when the system battery is fully discharged. In the case of a discharged system battery,  $V_{BUS\_SYS}$  can be used to power the system when a source with voltage between  $V_{UVLO}$  and  $V_{OVP}$  is attached to  $V_{BUS\_CON}$ .

### 9.2.1.3 Application Curves

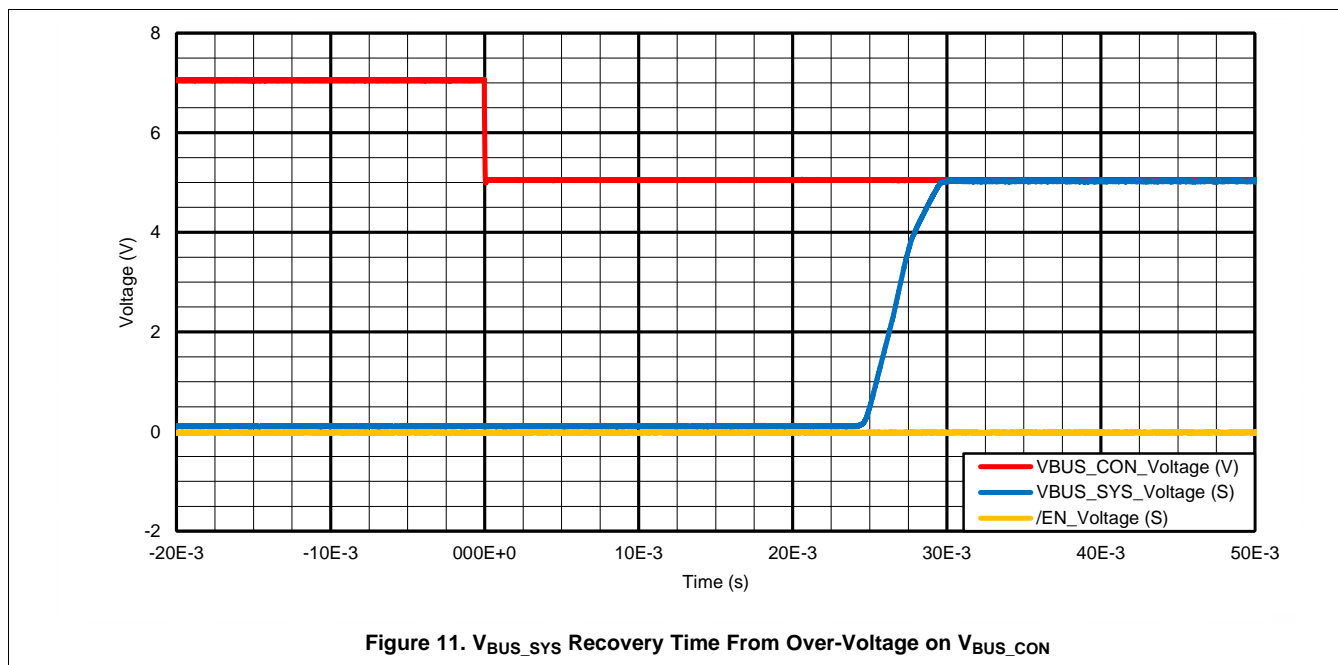

### 9.2.2 TPD1S514-1 USB 2.0/3.0 Case 2: PMIC Controlled $\overline{EN}$

TPD1S514 offers more flexibility to system designers to power up the system during a dead battery condition. Refer to [Figure 12](#), the  $V_{BUS\_POWER}$  pin supplies 4.95 V and 3 mA to power the PMIC in a dead battery condition. Regardless of  $\overline{EN}$  state,  $V_{BUS\_POWER}$  is available to the PMIC. Utilizing this power, the PMIC can enable TPD1S514 when the valid  $V_{BUS\_CON}$  voltage is present.

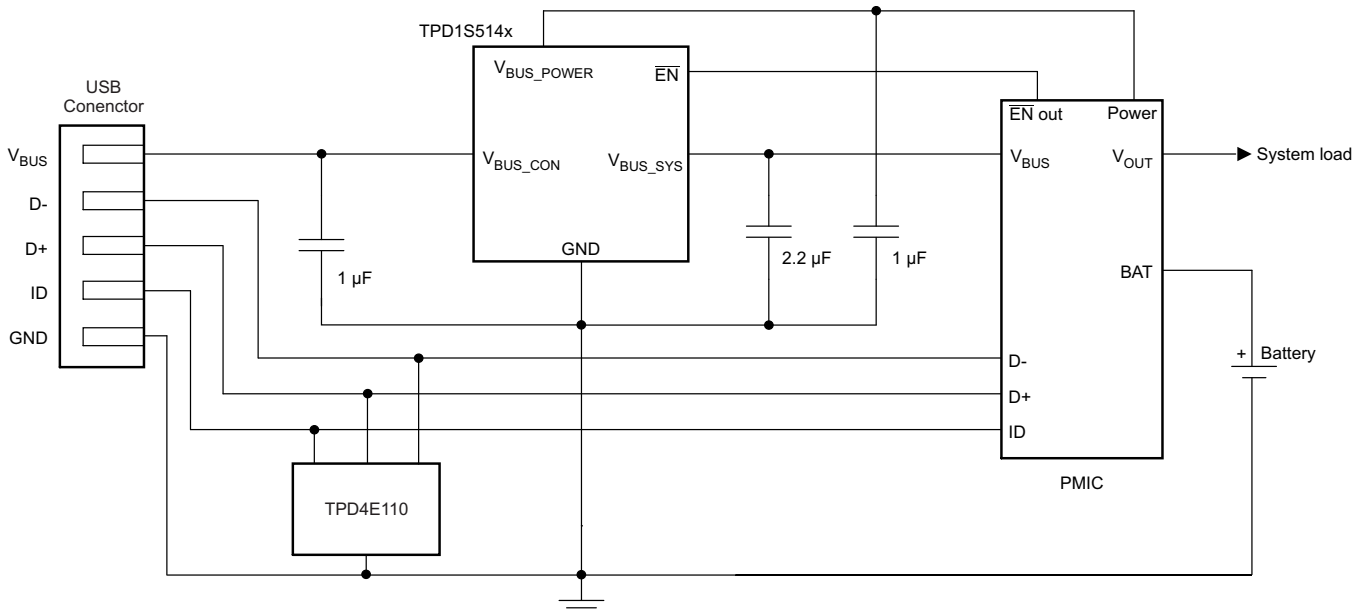

Figure 12. PMIC Controlled  $\overline{EN}$ , TPD1S514-1

#### 9.2.2.1 Design Requirements

For this example, use the following table as input parameters:

Design Parameters	Example Value
Signal range on $V_{BUS\_CON}$	3.5 V – 5.9 V
Signal range on $V_{BUS\_SYS}$	3.9 V – 5.9 V
Drive $\overline{EN}$ low (enabled)	0 V – 0.8 V
Drive $\overline{EN}$ high (disabled)	1.2 V – 6.0 V

#### 9.2.2.2 Detailed Design Procedure

To begin the design process, some parameters must be decided upon. The designer needs to know the following:

- $V_{BUS}$  voltage range
- PMIC power requirement

##### 9.2.2.2.1 $V_{BUS}$ Voltage Range

The UVLO trip-point is a maximum 3.5 V and the OVP trip-point is a minimum 5.9 V. This provides some headroom for the USB 2.0 specified minimum 4.4 V (Low-power) or 4.75 V (Full-power) and 5.25 V maximum; or the USB 3.0 specified minimum 4.45 V and 5.25 V maximum.

##### 9.2.2.2.2 PMIC Power Requirement

The  $V_{BUS\_POWER}$  pin can source up to 3 mA of current and maintain a minimum 4.8 V, 4.95 V typical. TPD1S514-1 design provides an LDO regulator supplied voltage source which can be used to provide power to a PMIC when its internal battery supplied power is unavailable. When selecting a matching PMIC, ensure its power requirement can be met by the  $V_{BUS\_POWER}$  pin if designing for this scenario.

9.2.2.2.3 Discharged Battery

Powering the PMIC from  $V_{BUS\_POWER}$  allows logic control of the  $\overline{EN}$  pin to set TPD1S514-1 active and begin charging the battery and powering up the rest of the system.

9.2.2.3 Application Curves

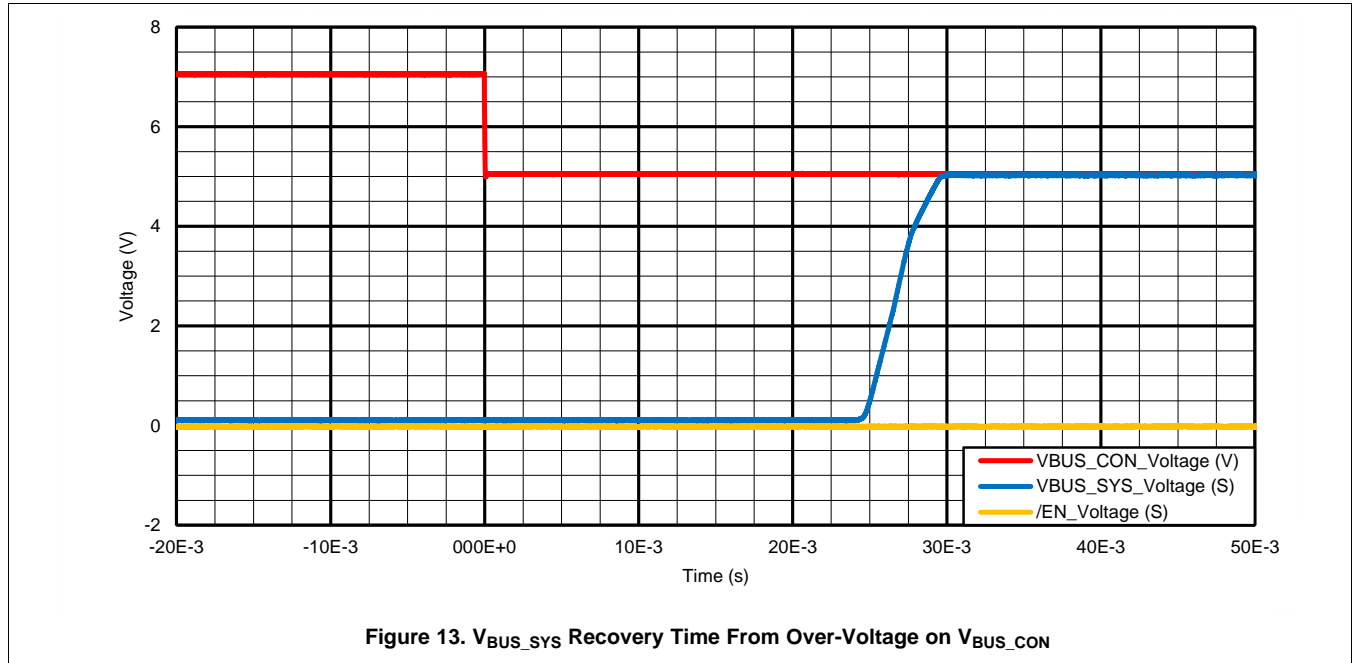

10 Power Supply Recommendations

TPD1S514 is designed to receive power from a USB 3.0 (or lower)  $V_{BUS}$  source. It can operate normally (nFET ON) between a minimum 3.5 V and a maximum  $V_{OVP\_MIN}$  V. Thus, the power supply (with a ripple of  $V_{RIPPLE}$ ) requirement for TPD1S514 to be able to switch the nFET ON is between  $3.5\text{ V} + V_{RIPPLE}$  and  $V_{OVP\_MIN} - V_{RIPPLE}$ , where  $V_{OVP\_MIN}$  is:

Device Name	$V_{OVP\_MIN}$
TPD1S514-1	5.90 V
TPD1S514-2	9.9 V
TPD1S514-3 (Preview)	13.2 V
TPD1S514-4	5.90 V

## 11 Layout

### 11.1 Layout Guidelines

- The optimum placement is as close to the connector as possible.
  - EMI during an ESD event can couple from the trace being struck to other nearby unprotected traces, resulting in early system failures.
  - The PCB designer needs to minimize the possibility of EMI coupling by keeping any unprotected traces away from the protected traces which are between the TVS and the connector.
- Route the protected traces as straight as possible.
- Eliminate any sharp corners on the protected traces between the TVS and the connector by using rounded corners with the largest radii possible.
  - Electric fields tend to build up on corners, increasing EMI coupling.

### 11.2 Layout Example

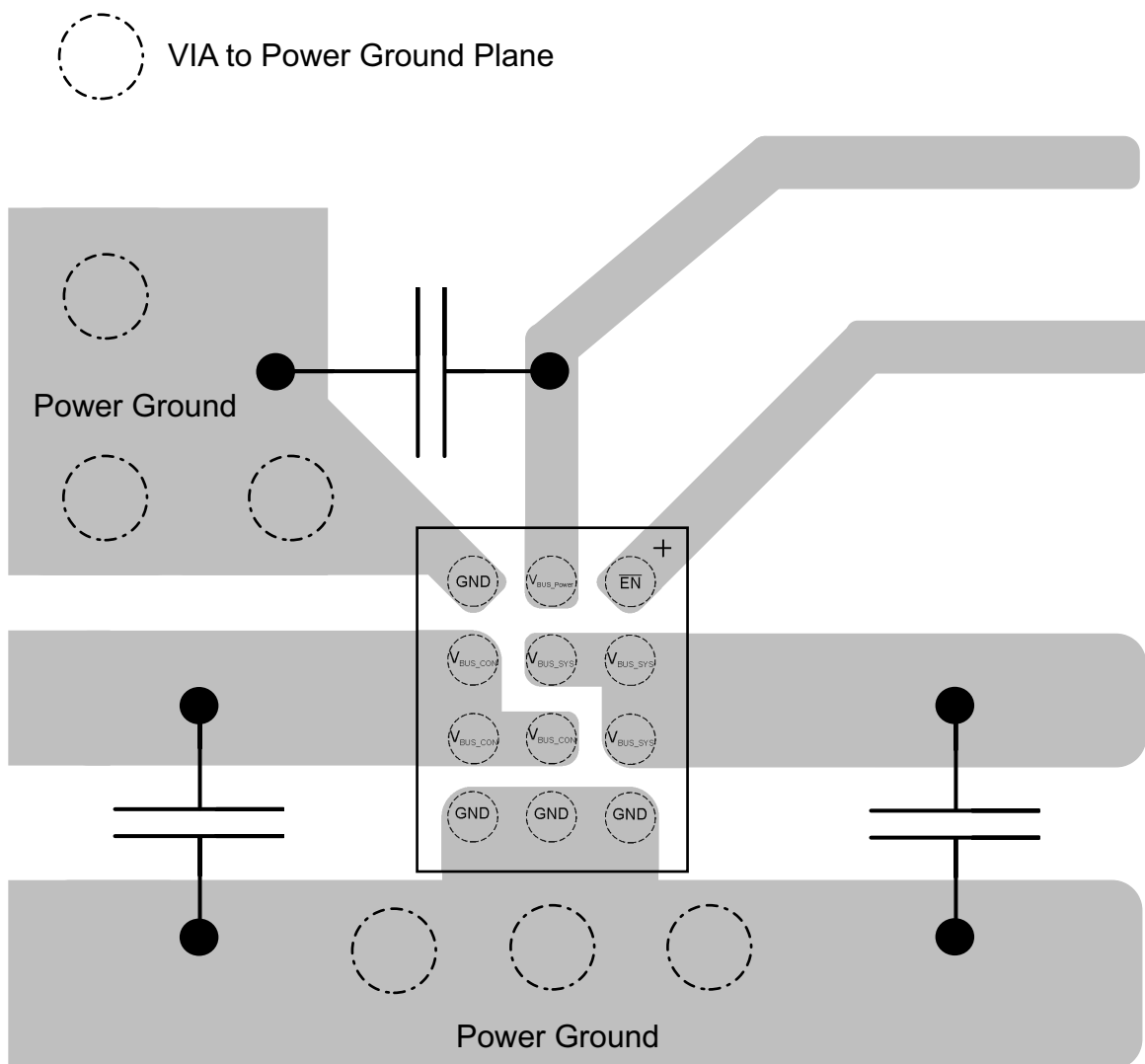

When designing layout for TPD1S514, note that  $V_{BUS\_CON}$  and  $V_{BUS\_SYS}$  pins allow extra wide traces for good power delivery. In the example shown, these pins are routed with 50 mil (1.27 mm) wide traces. Place the  $V_{BUS\_CON}$ ,  $V_{BUS\_SYS}$ , and  $V_{BUS\_POWER}$  capacitors as close to the pins as possible. Use external and internal ground planes and stitch them together with VIAs as close to the GND pins of TPD1S514 as possible. This allows for a low impedance path to ground so that the device can properly dissipate any surge or ESD events.

## 12 Device and Documentation Support

### 12.1 Trademarks

All trademarks are the property of their respective owners.

### 12.2 Electrostatic Discharge Caution



This integrated circuit can be damaged by ESD. Texas Instruments recommends that all integrated circuits be handled with appropriate precautions. Failure to observe proper handling and installation procedures can cause damage.

ESD damage can range from subtle performance degradation to complete device failure. Precision integrated circuits may be more susceptible to damage because very small parametric changes could cause the device not to meet its published specifications.

### 12.3 Glossary

[SLYZ022](#) — *TI Glossary*.

This glossary lists and explains terms, acronyms, and definitions.

## 13 Mechanical, Packaging, and Orderable Information

The following pages include mechanical packaging and orderable information. This information is the most current data available for the designated devices. This data is subject to change without notice and revision of this document. For browser-based versions of this data sheet, refer to the left-hand navigation.

**PACKAGING INFORMATION**

Orderable Device	Status (1)	Package Type	Package Drawing	Pins	Package Qty	Eco Plan (2)	Lead/Ball Finish (6)	MSL Peak Temp (3)	Op Temp (°C)	Device Marking (4/5)	Samples
TPD1S514-1YZR	ACTIVE	DSBGA	YZ	12	3000	Green (RoHS & no Sb/Br)	SNAGCU	Level-1-260C-UNLIM	-40 to 85	RH5141	<a href="#">Samples</a>
TPD1S514-2YZR	ACTIVE	DSBGA	YZ	12	3000	Green (RoHS & no Sb/Br)	Call TI   SNAGCU	Level-1-260C-UNLIM	-40 to 85	RH5142	<a href="#">Samples</a>

(1) The marketing status values are defined as follows:

**ACTIVE:** Product device recommended for new designs.

**LIFEBUY:** TI has announced that the device will be discontinued, and a lifetime-buy period is in effect.

**NRND:** Not recommended for new designs. Device is in production to support existing customers, but TI does not recommend using this part in a new design.

**PREVIEW:** Device has been announced but is not in production. Samples may or may not be available.

**OBsolete:** TI has discontinued the production of the device.

(2) Eco Plan - The planned eco-friendly classification: Pb-Free (RoHS), Pb-Free (RoHS Exempt), or Green (RoHS & no Sb/Br) - please check <http://www.ti.com/productcontent> for the latest availability information and additional product content details.

**TBD:** The Pb-Free/Green conversion plan has not been defined.

**Pb-Free (RoHS):** TI's terms "Lead-Free" or "Pb-Free" mean semiconductor products that are compatible with the current RoHS requirements for all 6 substances, including the requirement that lead not exceed 0.1% by weight in homogeneous materials. Where designed to be soldered at high temperatures, TI Pb-Free products are suitable for use in specified lead-free processes.

**Pb-Free (RoHS Exempt):** This component has a RoHS exemption for either 1) lead-based flip-chip solder bumps used between the die and package, or 2) lead-based die adhesive used between the die and leadframe. The component is otherwise considered Pb-Free (RoHS compatible) as defined above.

**Green (RoHS & no Sb/Br):** TI defines "Green" to mean Pb-Free (RoHS compatible), and free of Bromine (Br) and Antimony (Sb) based flame retardants (Br or Sb do not exceed 0.1% by weight in homogeneous material)

(3) MSL, Peak Temp. - The Moisture Sensitivity Level rating according to the JEDEC industry standard classifications, and peak solder temperature.

(4) There may be additional marking, which relates to the logo, the lot trace code information, or the environmental category on the device.

(5) Multiple Device Markings will be inside parentheses. Only one Device Marking contained in parentheses and separated by a "~" will appear on a device. If a line is indented then it is a continuation of the previous line and the two combined represent the entire Device Marking for that device.

(6) Lead/Ball Finish - Orderable Devices may have multiple material finish options. Finish options are separated by a vertical ruled line. Lead/Ball Finish values may wrap to two lines if the finish value exceeds the maximum column width.

**Important Information and Disclaimer:** The information provided on this page represents TI's knowledge and belief as of the date that it is provided. TI bases its knowledge and belief on information provided by third parties, and makes no representation or warranty as to the accuracy of such information. Efforts are underway to better integrate information from third parties. TI has taken and continues to take reasonable steps to provide representative and accurate information but may not have conducted destructive testing or chemical analysis on incoming materials and chemicals. TI and TI suppliers consider certain information to be proprietary, and thus CAS numbers and other limited information may not be available for release.

In no event shall TI's liability arising out of such information exceed the total purchase price of the TI part(s) at issue in this document sold by TI to Customer on an annual basis.

## TAPE AND REEL INFORMATION



### QUADRANT ASSIGNMENTS FOR PIN 1 ORIENTATION IN TAPE



\*All dimensions are nominal

Device	Package Type	Package Drawing	Pins	SPQ	Reel Diameter (mm)	Reel Width W1 (mm)	A0 (mm)	B0 (mm)	K0 (mm)	P1 (mm)	W (mm)	Pin1 Quadrant
TPD1S514-1YZR	DSBGA	YZ	12	3000	180.0	8.4	1.39	2.09	0.75	4.0	8.0	Q2
TPD1S514-2YZR	DSBGA	YZ	12	3000	180.0	8.4	1.39	2.09	0.75	4.0	8.0	Q2

**TAPE AND REEL BOX DIMENSIONS**

\*All dimensions are nominal

Device	Package Type	Package Drawing	Pins	SPQ	Length (mm)	Width (mm)	Height (mm)
TPD1S514-1YZR	DSBGA	YZ	12	3000	182.0	182.0	17.0
TPD1S514-2YZR	DSBGA	YZ	12	3000	182.0	182.0	17.0

## IMPORTANT NOTICE

Texas Instruments Incorporated and its subsidiaries (TI) reserve the right to make corrections, enhancements, improvements and other changes to its semiconductor products and services per JESD46, latest issue, and to discontinue any product or service per JESD48, latest issue. Buyers should obtain the latest relevant information before placing orders and should verify that such information is current and complete. All semiconductor products (also referred to herein as "components") are sold subject to TI's terms and conditions of sale supplied at the time of order acknowledgment.

TI warrants performance of its components to the specifications applicable at the time of sale, in accordance with the warranty in TI's terms and conditions of sale of semiconductor products. Testing and other quality control techniques are used to the extent TI deems necessary to support this warranty. Except where mandated by applicable law, testing of all parameters of each component is not necessarily performed.

TI assumes no liability for applications assistance or the design of Buyers' products. Buyers are responsible for their products and applications using TI components. To minimize the risks associated with Buyers' products and applications, Buyers should provide adequate design and operating safeguards.

TI does not warrant or represent that any license, either express or implied, is granted under any patent right, copyright, mask work right, or other intellectual property right relating to any combination, machine, or process in which TI components or services are used. Information published by TI regarding third-party products or services does not constitute a license to use such products or services or a warranty or endorsement thereof. Use of such information may require a license from a third party under the patents or other intellectual property of the third party, or a license from TI under the patents or other intellectual property of TI.

Reproduction of significant portions of TI information in TI data books or data sheets is permissible only if reproduction is without alteration and is accompanied by all associated warranties, conditions, limitations, and notices. TI is not responsible or liable for such altered documentation. Information of third parties may be subject to additional restrictions.

Resale of TI components or services with statements different from or beyond the parameters stated by TI for that component or service voids all express and any implied warranties for the associated TI component or service and is an unfair and deceptive business practice. TI is not responsible or liable for any such statements.

Buyer acknowledges and agrees that it is solely responsible for compliance with all legal, regulatory and safety-related requirements concerning its products, and any use of TI components in its applications, notwithstanding any applications-related information or support that may be provided by TI. Buyer represents and agrees that it has all the necessary expertise to create and implement safeguards which anticipate dangerous consequences of failures, monitor failures and their consequences, lessen the likelihood of failures that might cause harm and take appropriate remedial actions. Buyer will fully indemnify TI and its representatives against any damages arising out of the use of any TI components in safety-critical applications.

In some cases, TI components may be promoted specifically to facilitate safety-related applications. With such components, TI's goal is to help enable customers to design and create their own end-product solutions that meet applicable functional safety standards and requirements. Nonetheless, such components are subject to these terms.

No TI components are authorized for use in FDA Class III (or similar life-critical medical equipment) unless authorized officers of the parties have executed a special agreement specifically governing such use.

Only those TI components which TI has specifically designated as military grade or "enhanced plastic" are designed and intended for use in military/aerospace applications or environments. Buyer acknowledges and agrees that any military or aerospace use of TI components which have **not** been so designated is solely at the Buyer's risk, and that Buyer is solely responsible for compliance with all legal and regulatory requirements in connection with such use.

TI has specifically designated certain components as meeting ISO/TS16949 requirements, mainly for automotive use. In any case of use of non-designated products, TI will not be responsible for any failure to meet ISO/TS16949.

### Products

Audio	<a href="http://www.ti.com/audio">www.ti.com/audio</a>
Amplifiers	<a href="http://amplifier.ti.com">amplifier.ti.com</a>
Data Converters	<a href="http://dataconverter.ti.com">dataconverter.ti.com</a>
DLP® Products	<a href="http://www.dlp.com">www.dlp.com</a>
DSP	<a href="http://dsp.ti.com">dsp.ti.com</a>
Clocks and Timers	<a href="http://www.ti.com/clocks">www.ti.com/clocks</a>
Interface	<a href="http://interface.ti.com">interface.ti.com</a>
Logic	<a href="http://logic.ti.com">logic.ti.com</a>
Power Mgmt	<a href="http://power.ti.com">power.ti.com</a>
Microcontrollers	<a href="http://microcontroller.ti.com">microcontroller.ti.com</a>
RFID	<a href="http://www.ti-rfid.com">www.ti-rfid.com</a>
OMAP Applications Processors	<a href="http://www.ti.com/omap">www.ti.com/omap</a>
Wireless Connectivity	<a href="http://www.ti.com/wirelessconnectivity">www.ti.com/wirelessconnectivity</a>

### Applications

Automotive and Transportation	<a href="http://www.ti.com/automotive">www.ti.com/automotive</a>
Communications and Telecom	<a href="http://www.ti.com/communications">www.ti.com/communications</a>
Computers and Peripherals	<a href="http://www.ti.com/computers">www.ti.com/computers</a>
Consumer Electronics	<a href="http://www.ti.com/consumer-apps">www.ti.com/consumer-apps</a>
Energy and Lighting	<a href="http://www.ti.com/energy">www.ti.com/energy</a>
Industrial	<a href="http://www.ti.com/industrial">www.ti.com/industrial</a>
Medical	<a href="http://www.ti.com/medical">www.ti.com/medical</a>
Security	<a href="http://www.ti.com/security">www.ti.com/security</a>
Space, Avionics and Defense	<a href="http://www.ti.com/space-avionics-defense">www.ti.com/space-avionics-defense</a>
Video and Imaging	<a href="http://www.ti.com/video">www.ti.com/video</a>

### TI E2E Community

[e2e.ti.com](http://e2e.ti.com)